

# HCR3e Series Specifications

Models	Head	Needle	Needle Distance	Embroidery field per Head (DxW)				Max Speed (RPM)	
				Normal	Tublar	Cap Frame Wide	Cap Frame Low-Profile	Normal	Cap
HCR3e-1502	2	15	500mm	450x500mm	420x440mm	80x360mm	70x180mm	1100	850
HCR3e-1504	4		360mm	450x360mm	320x320mm				
HCR3e-X1504	4		500mm	450x500mm	420x440mm				
HCR3e-1506	6		360mm	450x360mm	320x320mm				
HCR3e-X1506	6		500mm	450x500mm	420x440mm				
HCR3e-1508	8		360mm	450x360mm	320x320mm				

Machine Sizes		
Models	Weight	Length
HCR3e-1502	480kg	1980mm
HCR3e-1504	560kg	2280mm
HCR3e-X1504	800kg	3000mm
HCR3e-1506	840kg	3000mm
HCR3e-X1506	1030kg	3980mm
HCR3e-1508	1070kg	3980mm

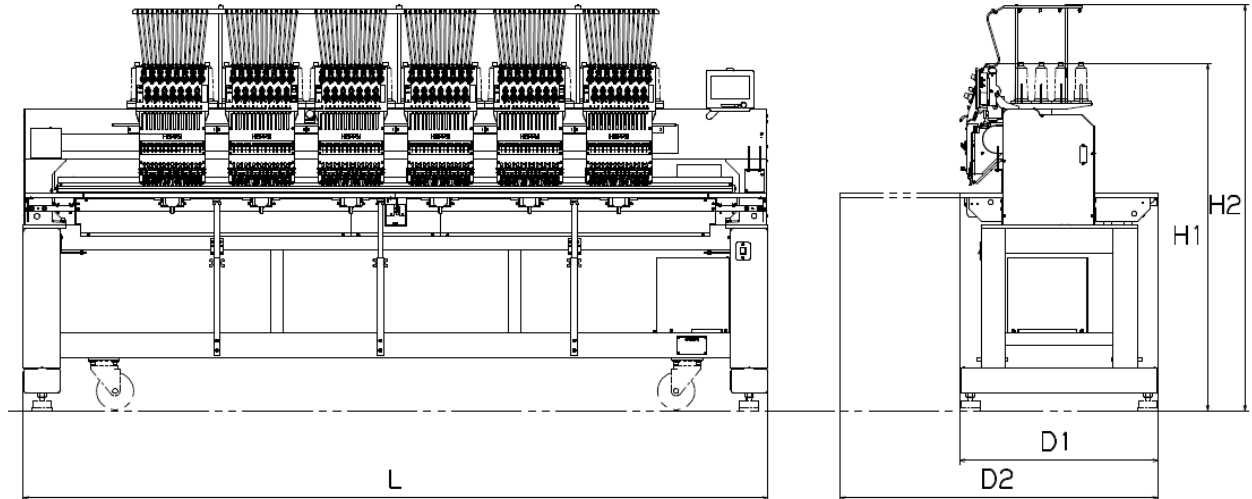

Common Dimintins for all Model			
D1	D2	H1	H2
830mm	1320mm	1510mm	1740mm

\*D2 = Distance including Table

\*H2 = Height including Thread Stand